

#CPP7423 Installation Instructions

Front Sway Bar for 1963-72 Chevy Truck

Instructions:

1. Check that the correct sway bar frame brackets are on the frame. Some trucks do not have the frame brackets on the frame that are used to attach a sway bar. If your truck does not have this bracket you will need to install this bracket. If the truck is using stock height springs you will want to use the OE (taller) bracket. If the truck has dropped springs or air bags you will want to use the short brackets. If you need to change the brackets simply remove the old bracket and install the new bracket. If your truck does not have brackets Step 5 will explain how to install them. Refer to the illustration.
2. Assemble the end links to the sway bar and the lower control arms. If there is more than one hole in the arm for the end link use the hole that makes the end link as close as possible to straight up and down.
3. Coat the inside of the pivot bushings with the supplied grease.
4. Install the pivot bushings on the sway bar. Position the sway bar mounting bracket over the pivot bushings so that the brackets are under the frame.
5. If the frame brackets need to be installed bolt the frame brackets to the sway bar bracket. With the suspension at ride height position the frame brackets under the frame so the end links are as close as possible to straight up and down. Mark the location for the mounting holes and drill the holes into the frame. Bolt the frame bracket to the frame.
6. If the frame brackets are already on the frame, bolt the sway bar brackets to the frame.
7. Install the grease fittings into the sway bar brackets.
8. Be sure to road test the truck so you can familiarize yourself with the truck's new handling characteristics.

PLEASE NOTE: The installer needs to make sure that nothing can make contact with a brake hose, caliper, or other brake component at any point through the entire range of steering and suspension movement. The installer also needs to make sure none of the steering or braking components can become bound or jammed at any time through the range of suspension or steering movement.

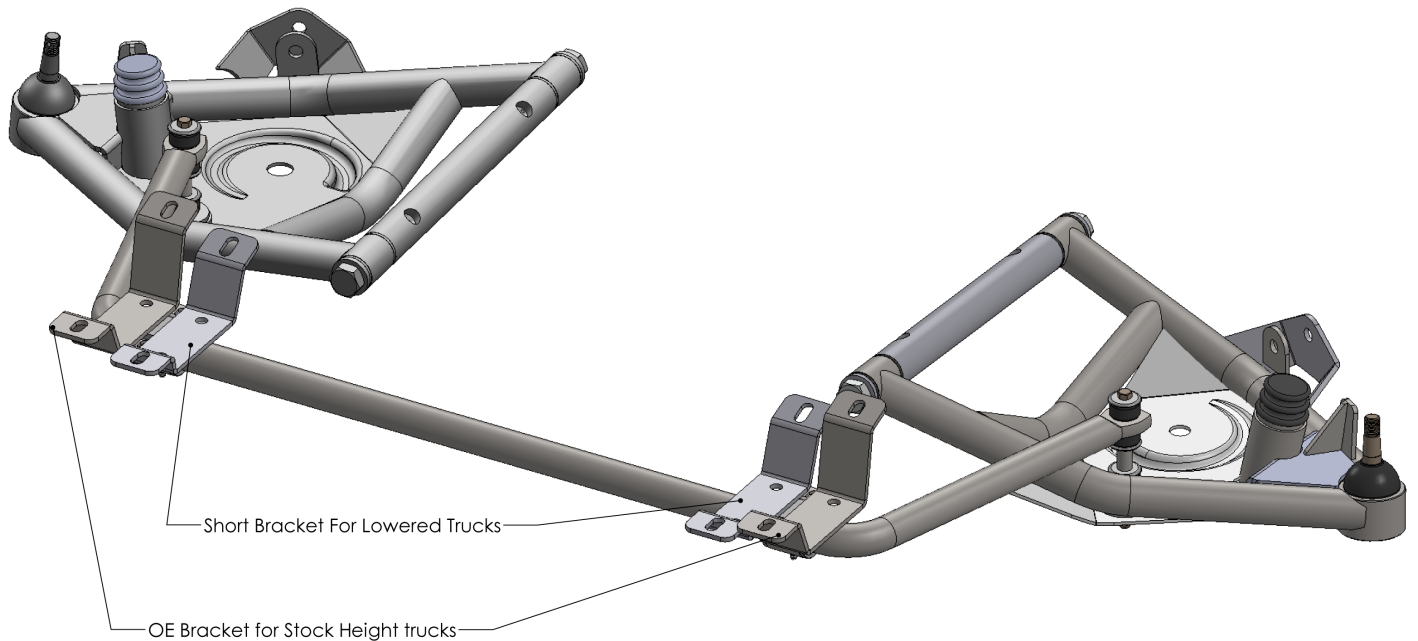

© Classic Performance Products, Inc. 2015
All rights reserved. This document may not be reproduced without prior written permission of CPP.

GENERAL TORQUE SPECIFICATIONS:

1/4"	grade 5	10lb/ft	1/4"	grade 8	14lb/ft
5/16"	grade 5	19lb/ft	5/16"	grade 8	29lb/ft
3/8"	grade 5	33lb/ft	3/8"	grade 8	47lb/ft
7/16"	grade 5	54lb/ft	7/16"	grade 8	78lb/ft
1/2"	grade 5	78lb/ft	1/2"	grade 8	119lb/ft
9/16"	grade 5	114lb/ft	9/16"	grade 8	169lb/ft
5/8"	grade 5	154lb/ft	5/8"	grade 8	230lb/ft

NOTE: With 18" and larger wheels we recommend 1/2" wheel studs. The larger the wheel diameter, the greater the force is on the wheel studs. Please inquire about replacement wheel stud kits available from CPP.