

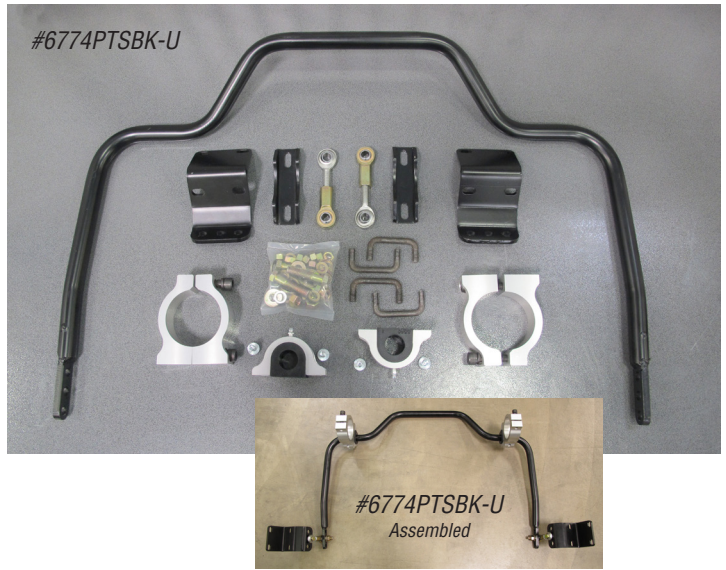

Steering, Brake & Suspension Specialists

#6774PTSBK & #6774PTSBK-U - Instructions

for 1967-69 Camaro & 1968-74 Nova Pro-Touring Rear Sway Bars

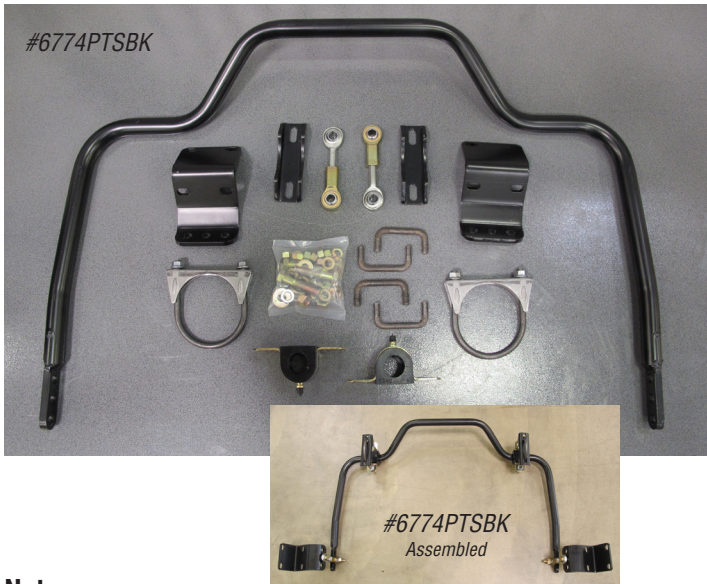

Notes:

It may be necessary to remove the rear wheels in order to access the upper frame area to drill the required holes for the sway bar end link brackets. Some aftermarket exhaust/mufflers may interfere with bar/bracket placement; ensure fitment and perform any adjustments before installation. If using the upgraded mount kit, the billet-aluminum axle clamp is designed to fit 2-3/4" to 3" diameter rear end housings; it will not fit smaller 2-1/2" housings such as an 8-inch Ford.

Instructions:

1. If possible, perform the job with the vehicle under its own weight (on ground or drive-on lift); otherwise, safely support using jack stands.
2. For billet axle clamps, coat socket head Allens with antiseize. (Fig 2)
3. Coat the sway bar pivot/D-bushings with grease and install onto sway bar. (Fig 3/4)



4. Set the sway bar mounting brackets onto the bushings centering the nipple into the zerk fitting hole (don't forget to install zerk fittings as well).
5. Install standard axle clamp U-bolts onto rear end housing; connect sway bar with D-bushing bracket and lower axle clamp. Dip in bar will be down and towards the rear. (Fig 5)



6. For billet clamps, assemble the two-piece axle housing clamp around the axle, with the bolt heads facing toward the rear and the flat D-bushing bracket-mounting surfaces pointing down. (Fig 6)
7. Loosely attach the sway bar with the D-bushings to the axle clamp; the dip in the bar will be down and towards the rear. (Fig 7)

Continued on next page

#6774PTSBK & #6774PTSBK-U - Instructions (Continued)

8. The billet lower sway bar clamps cannot be fully tightened until the axle housing clamps are set and tightened, as the Allen heads will interfere with hex bolts. (Fig 8) This will need to be redone at the end after final adjustment.



9. Install the Heim-joint end links onto the ends of the sway bar (center hole), and holding bar parallel to the frame and/or ground, determine where the link brackets will attach



13. Securely attach bracket, making sure it's snug tight against both the bottom and the side of the framerail. Mark the corresponding side holes. (Fig 13)

14. Removal of the wheel will help provide access for drilling the side holes; an angled pneumatic drill will also make the job easier. (Fig 14)

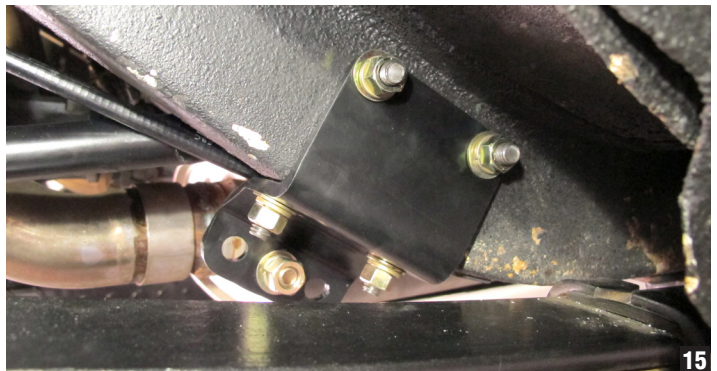

to the framerails. Typically, they will butt up against E-brake cable bracket. (Fig 9)

10. Drill the first 3/8" hole on the bottom side of the frame. (Fig 10)



15. With the bracket removed, insert the U-bolts through the holes with threaded ends protruding out the side. Reinstall bracket and securely tighten all four bolts. (Fig 15)

11. Use the U-bolt to mark and drill second hole, as bracket holes are slotted. (Fig 11)

12. Insert the U-bolt through the holes so that the threaded ends stick through the frame. (Fig 12)

Continued on next page



Steering, Brake & Suspension Specialists

#6774PTSBK & #6774PTSBK-U - Instructions (Continued)

16. Rotate axle clamps (billet or standard) until sway bar is as parallel to ground without bar contacting rear end and end links are perpendicular. Tighten clamp securely; add grease to D-bushing zerk fittings. (Fig 16)



17. With everything adjusted correctly, tighten up end link Heim joints. (Fig 17)

18. Reinstall wheels (torque lug nuts) and road test vehicle to familiarize yourself with the new sway bar.

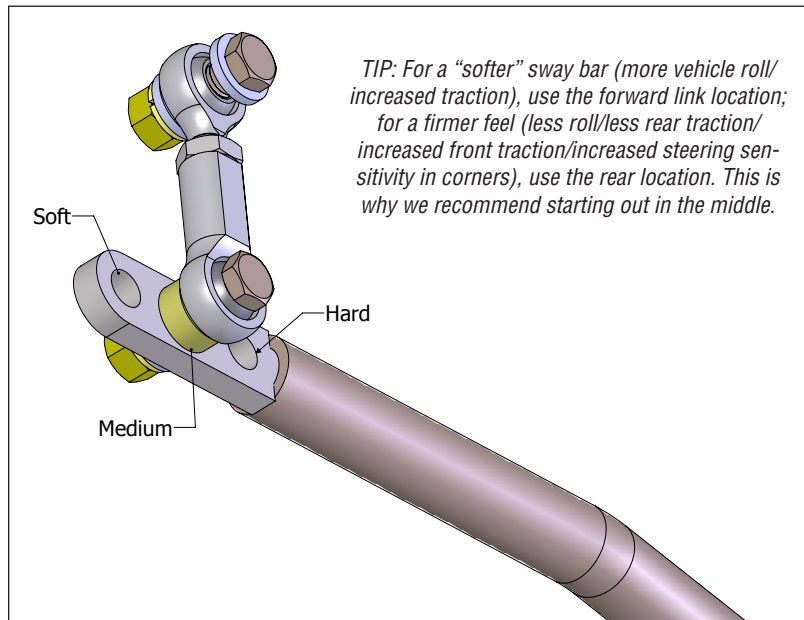
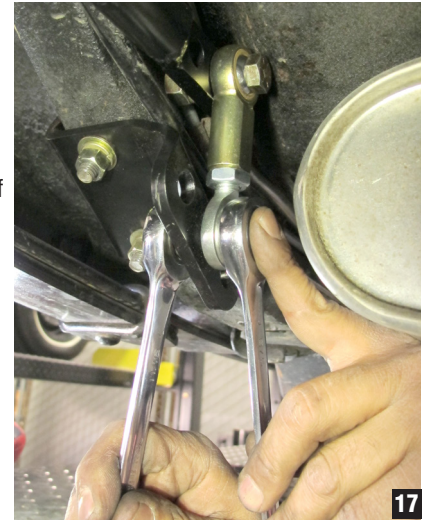

© Classic Performance Products, Inc. 2015
All rights reserved. This document may not be reproduced without prior written permission of CPP.

GENERAL TORQUE SPECIFICATIONS:					
1/4"	grade 5	10lb/ft	1/4"	grade 8	14lb/ft
5/16"	grade 5	19lb/ft	5/16"	grade 8	29lb/ft
3/8"	grade 5	33lb/ft	3/8"	grade 8	47lb/ft
7/16"	grade 5	54lb/ft	7/16"	grade 8	78lb/ft
1/2"	grade 5	78lb/ft	1/2"	grade 8	119lb/ft
9/16"	grade 5	114lb/ft	9/16"	grade 8	169lb/ft
5/8"	grade 5	154lb/ft	5/8"	grade 8	230lb/ft

NOTE: With 18" and larger wheels we recommend 1/2" wheel studs. The larger the wheel diameter, the greater the force is on the wheel studs. Please inquire about replacement wheel stud kits available from CPP.