

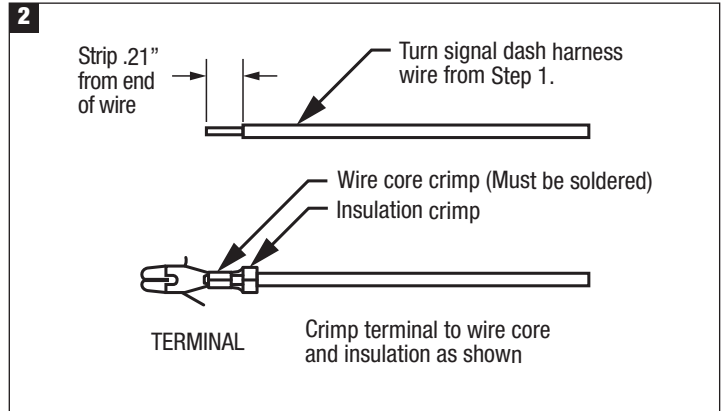

Steering, Brake & Suspension Specialists

#41382 - Hazard Warning Adapter Kit Instructions

Universal Fit

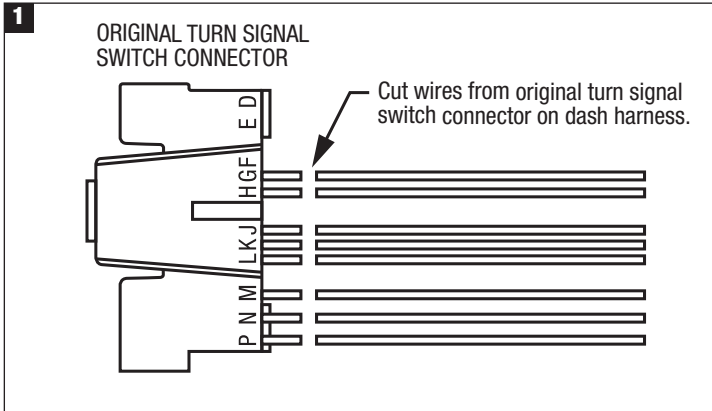

ATTENTION! READ FIRST!

Place the new harness next to the old harness and compare:

1. The color and length of wires
2. The type and size of each connector and terminal
3. The position of each wire in various connectors
4. The type & position of clips, clamps, and conduit covering (when applicable).

Instructions:

NOTE: Wire colors may be different from this instruction sheet, but the cavity function is the same. See Wire Function Chart below for more details.

1. Cut off wires from original turn signal switch connector on dash harness and strip .21" of insulation off the end of each wire.

2. Crimp a provided terminal on the end of each wire.

NOTE: After crimping, the wire core must be soldered to terminal.

3. Insert each terminal into the appropriate cavity of the hazard adapter wire connector.

4. Connect the hazard adapter BROWN wire to constant battery power source.

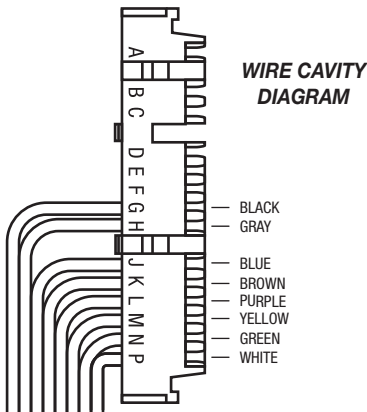
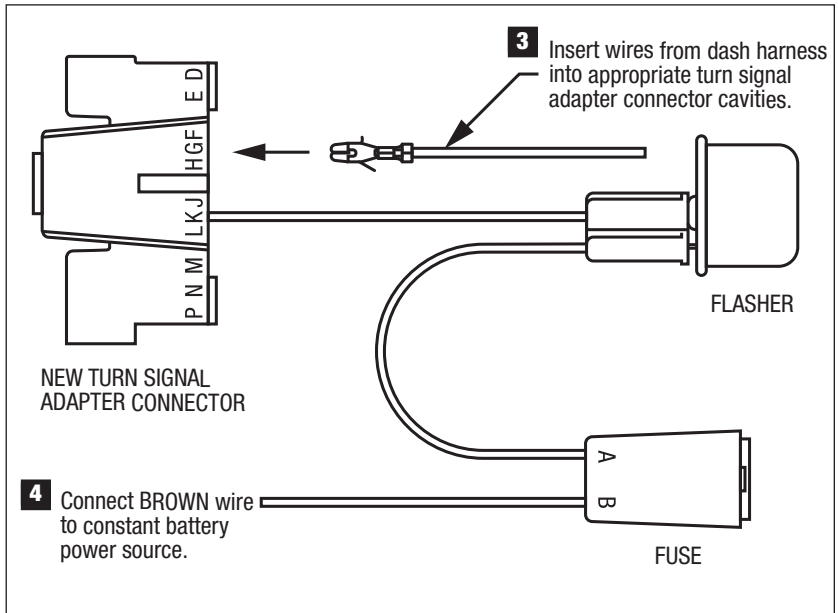

WIRE FUNCTION CHART (FOR REFERENCE ONLY)			
WIRE	WIRE COLOR	WIRE FUNCTION	NOTE:
G	BLACK	HORN	Wire colors may be different from this instruction sheet, but the cavity function is the same.
H	GRAY	LEFT FRONT TURN SIGNAL	
J	BLUE	RIGHT FRONT TURN SIGNAL	
K	BROWN	HAZARD	
L	PURPLE	TURN SIGNAL - POWER (MAIN)	
M	YELLOW	LEFT REAR TURN SIGNAL	
N	GREEN	RIGHT REAR TURN SIGNAL	
P	WHITE	BRAKE LIGHT	
--	BLACK	COLUMN SHIFT ONLY - ILLUMINATED GEARSHIFT INDICATOR IS CONNECTED TO DASH LIGHTS	